

---

# WESTERN<sup>®</sup>



GLOBAL



TRANSPORTABLE TANK

40, 50TCG

WM002-NA

# WHY WESTERN?

WITH AN INNOVATIVE RANGE OF SOLUTIONS BACKED BY  
A TEAM OF INDUSTRY EXPERTS, WESTERN GLOBAL  
FOCUSES ON MAKING YOU MORE PRODUCTIVE, MORE  
EFFICIENT AND ULTIMATELY MORE PROFITABLE.



# Contents

<b>INTRODUCTION .....</b>	<b>1</b>
<b>DESCRIPTION .....</b>	<b>2</b>
<b>SIGN-OFF FORM.....</b>	<b>6</b>
<b>IDENTIFICATION MARKS .....</b>	<b>4</b>
<b>UNIT SPECIFICATION .....</b>	<b>7</b>
<b>SAFETY .....</b>	<b>8</b>
<b>ACCESS AND SECURITY .....</b>	<b>12</b>
<b>CABINET OVERVIEW .....</b>	<b>13</b>
<b>CENTRE OF GRAVITY .....</b>	<b>14</b>
<b>LIFTING &amp; HANDLING .....</b>	<b>16</b>
<b>FILLING THE TCG .....</b>	<b>18</b>
<b>DISPENSING FUEL .....</b>	<b>19</b>
<b>TRANSPORTING .....</b>	<b>19</b>
<b>STACKING .....</b>	<b>20</b>
<b>STRAPPING CHARTS.....</b>	<b>21</b>
<b>MAINTENANCE AND SERVICE SCHEDULE .....</b>	<b>23</b>
<b>STATUTORY INSPECTION AND MAINTENANCE .....</b>	<b>24</b>
<b>INNER TANK REMOVAL.....</b>	<b>26</b>
<b>TORQUE SETTINGS.....</b>	<b>28</b>
<b>ENVIRONMENTAL RESPONSIBILITY .....</b>	<b>29</b>
<b>TROUBLE-SHOOTING .....</b>	<b>30</b>
<b>WARRANTY .....</b>	<b>31</b>

## INTRODUCTION

### Thank you for choosing Western Global



#### **Please read the contents of this manual before use.**

- Ensure all operators are fully conversant with the procedures for lifting, loading, positioning, filling, maintaining and use of the unit
- By understanding and following the information and procedures in this manual, your tank will give you many years of safe use
- Certain information in this manual is governed by Transportation of Dangerous Goods Act, regulations, codes and standards applicable for Storage & Transportation of Dangerous Goods. This is subject to change without prior notice. Great care has been taken to ensure that the information is correct at the time of publication.
- However, it is the owner's / user's sole responsibility to ensure that they and the tank fully comply with all regulatory and legal requirements. Western Global cannot and will not accept any liability for any inaccuracy or incorrectly stated legal requirements
- Western Global reserves the right to alter product specifications without prior notice or obligation

**Western Global Tanks are design approved under various Global / International / National Standards of safety<sup>1</sup>**

---

<sup>1</sup> Speak to your local / regional Western Global office for applicable standards.

## DESCRIPTION



### **(IBC) Intermediate Bulk Container**

**The 40TCG & 50TCG tanks have been designed to enable above ground safe storage and transportation of Flammable & Combustible fluids. In compliance to the CAN/CGSB-43.146-2016 (Design, manufacture and use of intermediate bulk containers for the transportation of dangerous goods, classes 3, 4, 5, 6.1, 8 and 9) as regulated by Transport Canada, the said tanks are also type approved as UN Standardized IBC for transportation of CLASS 3, Packing Group III (PG-III) Flammable and Combustible Liquids.**

- The 40TCG & 50TCG tanks conform to UN Standardized IBC as adopted by Transport Canada which allows the transportation of the unit containing fuel on the highway/road. There is no need to drain / empty the tank before transporting
- Meets UL 142 and CAN/ULC-S601-14 standard of safety for storage of flammable and combustible liquids
- The TCG can be used as an auxiliary fuel tank, feeding generators etc., and for refuelling other equipment via a dedicated fuel pump
- All pipe work and pump systems are stored beneath a secure, lockable cabinet lid
- To aid both transporting and handling, the TCG is fitted with forklift pockets and crane sling lifting points
- Internal baffles ensure safe control of fuel movement when the unit is being lifted or transported
- Containment (Bund) has a capacity equal to 110% of the main tank's capacity
- The design enables maintenance of the containment area without specialty equipment
- The TCG has a comprehensive range of connection points to enable attachment of various fittings and equipment
- The TCG can supply fuel to multiple feed lines
- According to the Transportation of Dangerous Goods Regulations (SOR/2001-286) as applicable in Canada, Marine Transport — Transportation of Dangerous Goods Regulations, Section 11.2, an UN Standardized IBC could be used for Marine Transport.

- 11.2 A person who imports, offers for transport, handles or transports dangerous goods by vessel must comply with these Regulations if the dangerous goods are in transport between
  - two points in Canada on a voyage during which the vessel is always within 120 nautical miles from shore and
    - on the Atlantic coast, the vessel does not go south of the port of New York, and
    - on the Pacific coast, the vessel does not go south of Portland, Oregon; or
  - Canada and another country if the voyage is an inland voyage.



## IDENTIFICATION MARKS

Each tank is supplied with 3 unique identification numbers.

1. UN IBC Serial Number
2. Manufacturing Serial Number
3. UL/ULC Serial Number

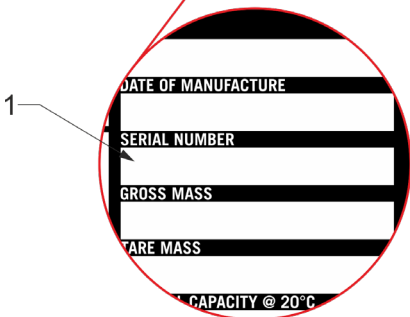
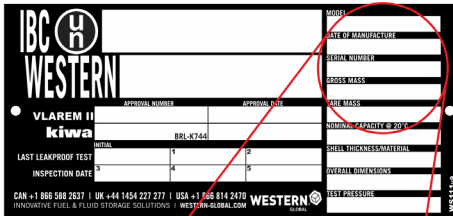

1, UN IBC Serial Number

The UN IBC Plate is located on the external of the tank (front or Side near the cabinet area

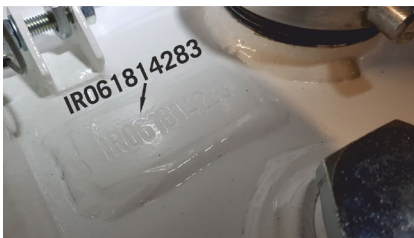

2, Manufacturing Serial Number

Tank number is positioned in the cab area and will be permanently attached to the main tank.

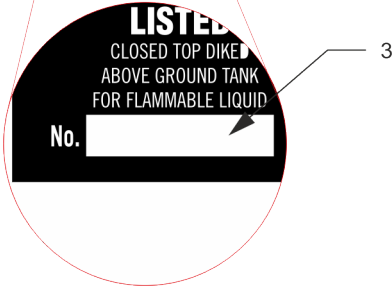
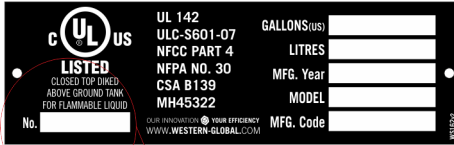

3, UL/ULC Serial Number

The UL Plate is located on the external of the tank (front or Side near the cabinet area)

Record your serial numbers here

UN IBC Data-plate Serial Number	
Manufacturing Serial Number	
UL/ULC Data plate Serial Number	
Plant Number*	

\*Optional customer plant number





# UNIT SPECIFICATION

## Capacities / Dimensions

Model	Capacity					
	Litres		US Gallon		Imp. Gallon	
	Nominal	Safe Fill @ 95%	Nominal	95%	Nominal	95%
40TCG	3782	3593	999	949	832	790
50TCG	4558	4330	1204	1144	1003	952

Model	Weight			
	KG		LBS	
	TARE	GROSS	TARE	GROSS
40TCG	1569	5162	3459	11380
50TCG	1680	6600	3704	14551

Model	Dimension					
	Metric (mm)			Imperial (Inch)		
	L	W	H	L	W	H
40TCG	2308	2308	1137	91	91	45
50TCG	2300	2300	1320	91	91	52

## UN Reference number

### UN Certificate of Packaging reference number TCG(G)

40TCG	31A/Y/** ***/CAN/WEC 4-527/9133/5351
50TCG	31A/Y/** ***/CAN/WEC 4-527/11225/6600

\*\* \*\* = MM YY of manufacture.

# SAFETY



**Before using this equipment and to avoid personal injury,  
carefully read and understand these instructions.**

## General

- If there is anything you do not understand, contact your supplier for advice
- The unit must be operated by authorised personnel only
- This unit must not be moved, filled, maintained or operated by persons who are under the influence of alcohol or drugs, tired or unwell
- You **MUST** perform a risk assessment before using this equipment to ensure your safety and the safety of others
- Wear the correct Personal Protective Equipment for the task you are performing
- Do not wear loose jewellery or clothing that may get in the way or become trapped in the mechanism
- Inspect the unit before use, if there is any doubt about its condition, **DO NOT USE IT**
- Do not smoke – No naked flames near tank
- Please follow all necessary Transportation of Dangerous Goods act, regulations and codes, National and Regional Fire Safety Codes, and other Installation Codes as applicable in your region / country of use.



No Smoking



No Open Flames



Authorised Access Only



Wear Safety Glasses



Wear Safety Helmet



Wear Ear Protection



Wear Safety Shoes



Wear Safety Gloves



Wear Coveralls

**NOTE: Please check with the local authority for any further site requirements or regional legislation. A full risk assessment may be required**

## Limitations of use

- The TCG is designed for the safe storage of Packing Group III Flammable & Combustible fluids, on site or in transit
- Each unit has a safe fill quantity which is 95% of its stated Nominal capacity

## Safe practice

The storage, transportation and dispensing of Flammable & Combustible fluids is governed by law and it is the user/operator who has sole responsibility to ensure that any such rules and regulations are abided by.

## Earthing point

- The unit is fitted with an earthing point. This can be found on bottom frame of the unit
- Used to protect against static electricity build up, this should be connected to a suitable earthing point, by a qualified electrician, when in use

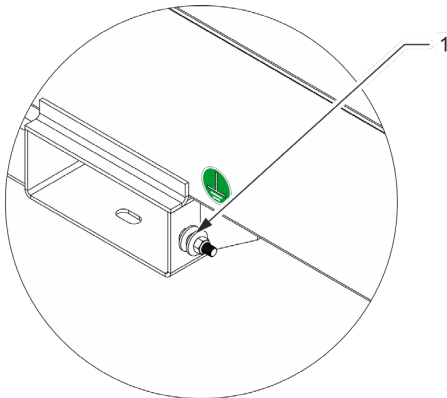

1. Earth point

## Venting

Each unit has 2 common vents installed; these are in the Cab Area of the tank.

**IMPORTANT: Do not operate the unit if these vents are damaged or missing**

- 2" Pressure Vacuum Vent – Allows movement of air into the unit at low pressure during the pumping process and allows air out of the unit at a higher pressure to stop an over pressure of the internal tank
- ¼" Roll over Vent – Allows free flow air into and out of the tank at all times, this low volume vent will fully close if the tank is inverted or turned on its side
- For stationary installation follow local regional, state and National Fire Safety Codes and other governing Installation Codes for the Normal and Emergency Venting equipment and appurtenances.

CONSULT WITH AUTHORITY HAVING JURISDICTION PRIOR TO INSTALLATION.

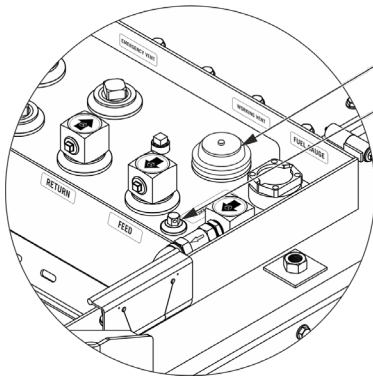

1. 2" Pressure / Vacuum Vent
2. ¼" Roll Over Vent

For compliance to the Fire Safety Codes as associated with Stationary Installations of Aboveground Storage Tanks,

**NORMAL VENT(S) & EMERGENCY VENT(S) SHALL BE INSTALLED PRIOR TO USE. DO NOT PLUG OR USE FOR ALTERNATE PIPING.**

## ACCESS AND SECURITY



**SAFETY. Ingress to the inner tank must only be carried out by trained personnel and after a full risk assessment has been carried out.**

### Access to the inner tank

For maintenance, inspection and cleaning, access can be made through the installed access lid located on the top of the tank.

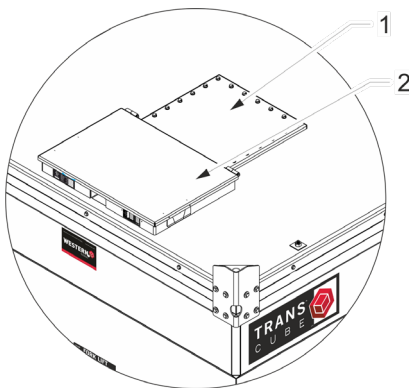

1. Access Lid
2. Cabinet hatch

### Access to the Cab Area

- The cabinet hatch is constructed of a heavy-duty steel, care should be taken when opening or closing
- The cabinet hatch should be kept closed when the TCG is not being used to protect the fittings and containment area from weather conditions.

### Security

- The TCG is fitted with a range of connections to enable the supply of Flammable & Combustible fluids. All the connections are housed behind the cabinet hatch, which can be locked using a suitable security padlock



## CABINET OVERVIEW

### Standard NA Unit

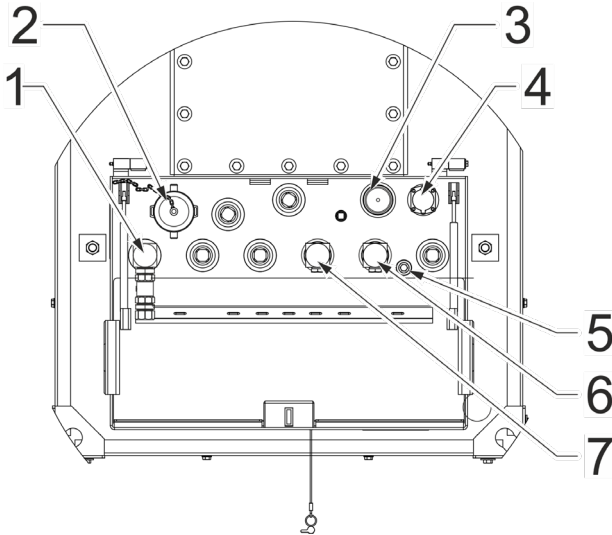

1. 1" Pump Feed
2. 3" NPTS Fill Point
3. 2"NPT Pressure / Vacuum vent
4. Fuel Gauge
5. ¼"NPT Roll Over Vent
6. ½" NPT Feed
7. ½" NPT Return

# CENTRE OF GRAVITY

## 40TCG Centre of Gravity<sup>2</sup>



Center Of Gravity

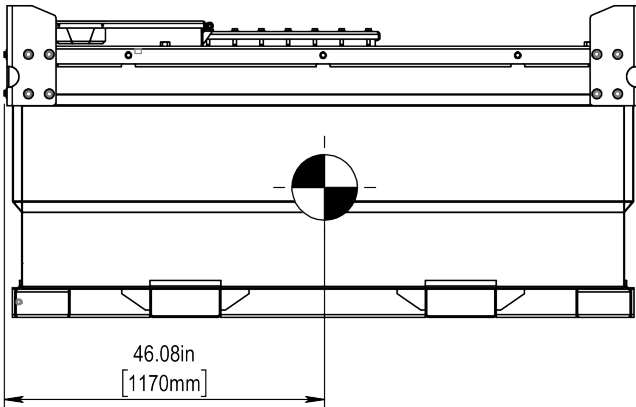
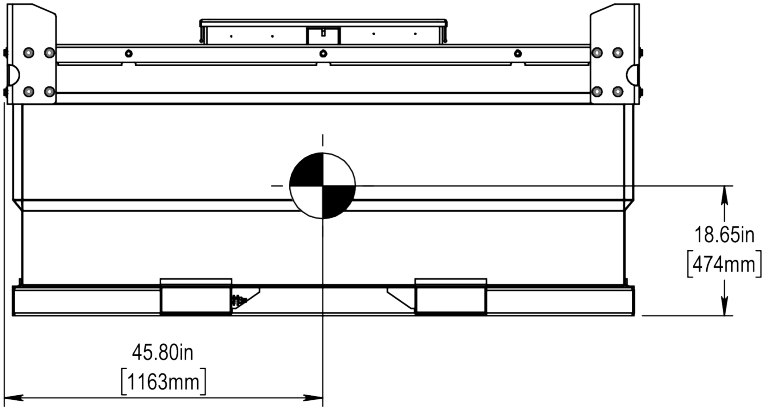

<sup>2</sup> Based on empty tank.

### 50TCG Centre of Gravity<sup>3</sup>



Centre Of Gravity

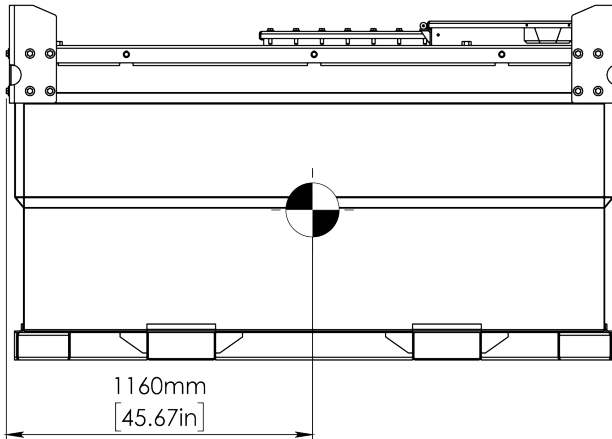
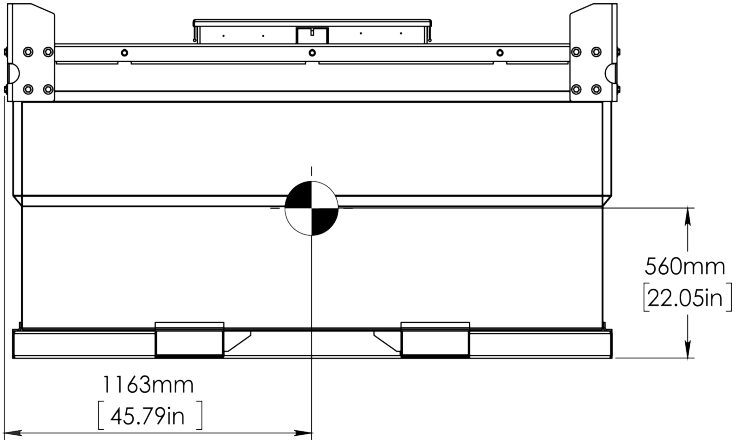

<sup>3</sup> Based on empty tank.

## LIFTING & HANDLING

### **IMPORTANT: Always prepare a Lifting Plan/Risk Assessment.**

#### By Forklift / Tele-handler

- Each TCG is fitted with forklift pockets which are designed to allow the TCG to be raised by a forklift/tele-handler. The TCG can be lifted from all 4 sides. This must be considered in your risk assessment
- It is important that the total gross weight of the TCG is not more than half (50%) of the forklift's maximum SWL. Ensure that the forklift's forks are set to the correct width for the TCG's fork pockets

#### By Crane

- Lifting of tanks should only be undertaken by a competently trained person
- You will require a lifting device (crane) and suitable four-leg chain slings fitted with hooks and safety catches
- Always check and obtain official confirmation from the chain sling supplier that it is both suitable in SWL and chain length
- With the chain slings correctly attached to the lifting equipment, attach each hook to the lifting points. Once attached, ensure the catches fitted to all hooks are closed
- Attach tag lines to the base of the unit to control rotation
- Lift the chains until taut and check that the hooks are correctly positioned with catch closed and that the chains are not twisted. If a fault is found, lower the chain and reattach correctly
- Lift the unit until just off the ground and check that it is balanced and stable. Once you are satisfied that everything is correctly and safely set up, you can continue with the lift.

### **The TCG must ONLY be lifted via the dedicated crane lifting point(s) found in each corner. See Lifting Points**

- ALL lifting point(s) must be used during a lift
- The lifting points MUST be inspected for condition and safe use
- DO NOT lift from the base, with polyester slings

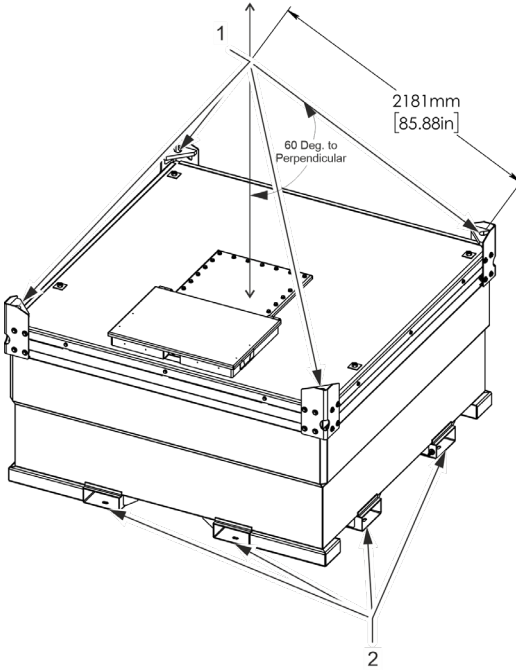

1. Lifting Points
2. Fork Pockets

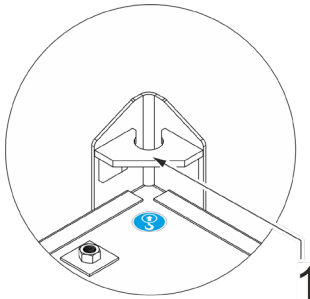

1. Lifting Point  
**LIFT HERE ONLY**

**WARNING**  
**Do not allow anyone under the raised load at any time or for any reason.**

- Use suitable tag lines to help control the movement of the unit and always keep constant communication with the crane operator
- Move slowly and smoothly to ensure full control of the unit's whereabouts
- Lower the unit to its required resting place using great care

## Positioning

Where the TCG is to be permanently positioned for use (long or short term) it is important that certain aspects are considered

- You should make sure that both supplying vehicle and receiving vehicle have safe and easy access to the TCG
- The position should be selected where the unit will be protected from accidental impact
- Consideration should be given to the location of overhead services such as telecommunications, power cables and overhanging obstructions. Be aware of the location of underground services, such as drains, and manhole covers
- You must also consider the ground surface and make sure it can support the weight of the TCG, its contents when full and any stored equipment such as pumps, without the risk of subsidence. It should be positioned on smooth and level ground with access available to the rear and sides
- Allow for access that may be required by the emergency services should it become necessary
- CONSULT WITH AUTHORITY HAVING JURISDICTION PRIOR TO INSTALLATION.

## FILLING THE TCG

- **DO NOT FILL TANK WHEN DISPENSING IS IN OPERATION**
- Only fill the TCG to 95% of its nominal capacity
- Filling should only be performed by a suitably trained person and only following a full risk assessment
- The TCG must be positioned on a firm level surface, whether static, truck or trailer mounted
- Where truck or trailer mounted, ensure that the parking brake is set to ON and the wheels are chocked
- Before filling, ensure that you have a suitable spill containment kit and that you are wearing all required PPE
- Nozzle Fill - Unscrew and remove the 3" filler cap, place the filling nozzle in the 3" port.
- Hard Couple fill (EU Only) - Unscrew and remove the 2" filler cap, connect the 2" delivery hose. Remove the 3" cap to allow venting
- **Do not leave the nozzle unattended during the filling process**
- Observe the fuel level gauge for an indication of tank capacity, then once filled, replace the filler cap and clean up any spills

## DISPENSING FUEL

There are two options available for dispensing/supplying fuel. Either manually via a fuel pump and nozzle or by direct coupling to the equipment such as a generator.

### 1. By Fuel Pump

For the information about any pump system fitted to this TCG, please refer to documents supplied with the pump.

### 2. Direct Coupling

enables continuous fuel feed to equipment such as generators where fuel is required continuously.

## TRANSPORTING

- **When transporting ALL ports, valves and vents must be closed**
- Ensure pump is turned off
- Close and lock the access lid
- The TCG must be secured firmly to its means of transport
- Use tie down points shown below

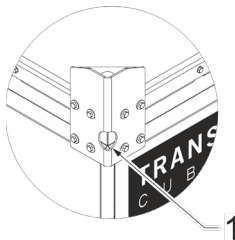

1. Tie Down Point

Each TCG incorporates baffle plates, these are situated in the inner tank. The baffle plates are designed to restrain and regulate the flow of fluid and remove the risk of damage to the tank during transport.

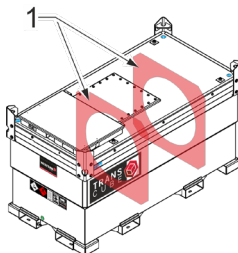

1. Baffles



The baffle plates run the width of the unit and are only effective if the tank is loaded correctly onto the trailer, truck etc. NOTE: always load the tank as shown below with the cabinet running in the direction of travel.

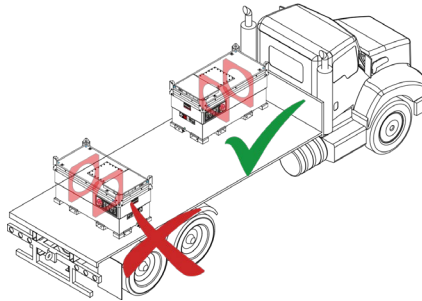

**IMPORTANT**



**When transporting ALL ports, valves, vents and openings must be closed**

## MARKINGS

For compliance to the Transportation of Dangerous Goods Act and regulations, and to comply to the National Fire Protection Association, necessary UN # CLASS-3 Diamond Placards and NFPA "hazard diamond" must be displayed. These markings convey health warning information to emergency response teams.

## STACKING

- The TCG is designed with the structural strength to allow stacking 2 high when full and 3 high when empty.
- Always mate the corner brackets together to stabilise the stack.
- Use only a hoist or forklift with the required lift capacity to raise, lower or stack the tanks.

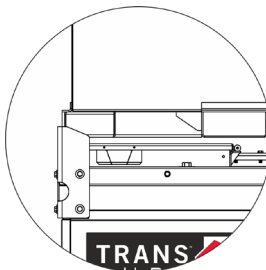

Stacking Arrangement

# STRAPPING CHARTS

## 40TCG

Depth (mm)	Depth (in)	Fuel Level (Litre)	Fuel Level (US Gallon)	Fuel Level (Imp Gallon)
45	1.8	206	54.4	45.3
90	3.5	412	108.8	90.6
135	5.3	619	163.5	136.1
180	7.1	825	217.9	181.5
225	8.9	1031	272.4	226.9
270	10.6	1238	326.9	272.2
315	12.4	1444	381.4	317.6
360	14.2	1650	435.9	363.0
405	15.9	1855	490.0	408.0
450	17.7	2057	543.3	452.4
495	19.5	2255	595.7	496.1
540	21.3	2451	647.4	539.1
585	23.0	2643	698.2	581.4
630	24.8	2832	748.2	623.0
675	26.6	3019	797.5	664.0
720	28.3	3202	845.9	704.3
765	30.1	3382	893.5	744.0
<b>806</b>	<b>31.7</b>	<b>3546</b>	<b>936.8</b>	<b>780.0</b>
810	31.9	3559	940.3	782.9
855	33.7	3733	986.3	821.2
900	35.4	3904	1031.4	858.8

1. Highlighted on the strapping chart is the maximum safe fill level @ 95% of the nominal volume. **DO NOT FILL ABOVE THIS LEVEL**
2. The dip chart volume is taken from the lowest point in the tank.
3. When programming a level monitoring system, the difference in floor height at the port location (where the instrument is mounted) should be subtracted from the fill height for each volume increment line to equate to corresponding fill height at the instrument location.

## 50TCG

Depth (mm)	Depth (in)	Fuel Level (Litre)	Fuel Level (US Gallon)	Fuel Level (Imp Gallon)
55	2.2	252	66.6	55.4
110	4.3	504	133.1	110.9
165	6.5	756	199.8	166.4
220	8.7	1008	266.4	221.8
275	10.8	1261	333.0	277.3
330	13.0	1513	399.6	332.7
385	15.2	1765	466.2	388.2
440	17.3	2017	532.8	443.6
495	19.5	2269	599.4	499.1
550	21.7	2521	666.0	554.5
605	23.8	2770	731.7	609.3
660	26.0	3014	796.3	663.1
715	28.1	3254	859.6	715.8
770	30.3	3489	921.8	767.5
825	32.5	3720	982.7	818.3
880	34.6	3946	1042.4	868.0
935	36.8	4168	1100.9	916.7
<b>976</b>	<b>38.4</b>	<b>4330</b>	<b>1143.9</b>	<b>952.5</b>
990	39.0	4384	1158.2	964.4
1045	41.1	4558	1204.2	1002.7

1. Highlighted on the strapping chart is the maximum safe fill level @ 95% of the nominal volume. DO NOT FILL ABOVE THIS LEVEL
2. The dip chart volume is taken from the lowest point in the tank.
3. When programming a level monitoring system, the difference in floor height at the port location (where the instrument is mounted) should be subtracted from the fill height for each volume increment line to equate to corresponding fill height at the instrument location.

## MAINTENANCE AND SERVICE SCHEDULE

V = Visual inspection P = Physical Check L = Lubricate R = Replace							
Item	Daily	Weekly	Monthly	6 Monthly	Yearly	Other	Reference / Comments
General							
Housekeeping		V		P			Check site and tank. Remove debris etc.
Firefighting media (if fitted)		V		P			V = Check in place and unused P = Test pressure and function
Doors			V		L		V = Visual inspection L = Greases hinges
Signage			V/R				Check damage and wear
Tank							
Ball valves		P					P = Check operation
Vents, fittings and pipelines		V		P			V = Visual checks for leaks and damage P = physical check, bolt tightness, paint deterioration
Interstitial space (Containment)		P					Check for water or product
Tank earthing				V	P		V = Visual check OK P = Test continuity
Level gauges		V			P		V = Visual checks for leaks and damage P = Remove and check operation

## STATUTORY INSPECTION AND MAINTENANCE

To retain the UN IBC approval<sup>4</sup>, it is required that the owner of the TCG carries out regular inspections and ensures that a record of each inspection is kept. Where fault is found, the unit **MUST** be removed from service until the fault is rectified and the unit is retested successfully.

### Every 2 ½ years

- External inspection
- Function of all services equipment
- Leak test.

### Every 5 years

- Internal inspection
- External inspection
- Function of all services equipment
- Leak test.

**NOTE: The 2 ½ and 5-year Inspection must be carried out by a competent person**

---

<sup>4</sup> For Canada – Transport Canada approved and Registered testing facility with valid certification under CAN/CGSB43.146-2016.



## INNER TANK REMOVAL

For periodic inspection you may be required to remove the inner tank from the containment. Follow local Health and Safety rules when carrying out this operation.

**IMPORTANT - Ensure the tank is empty before lifting.**

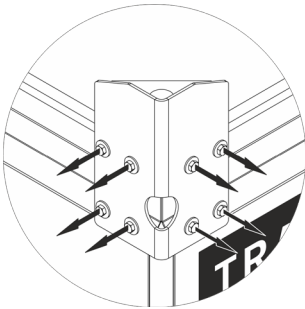

1. Remove all 4 corner brackets. Store brackets, nuts and bolts safely

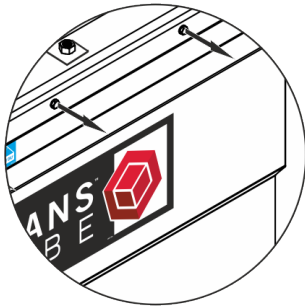

2. Remove 2 x side and 2 x end rails. Store rails, nuts and bolts safely

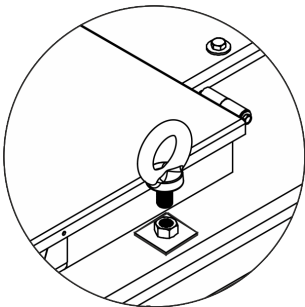

3. Insert 4 x M22 lifting eyes in each corner of the inner tank



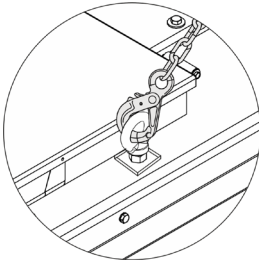

4. Using a 4-leg lifting chain attached to each corner carefully remove the inner tank

To re-install the inner tank into the containment, follow steps 1 – 4 in reverse. Always ensure the bolts are torqued.

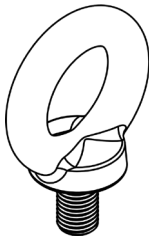

Typical Lifting Eye M22 x 2.5 Pitch

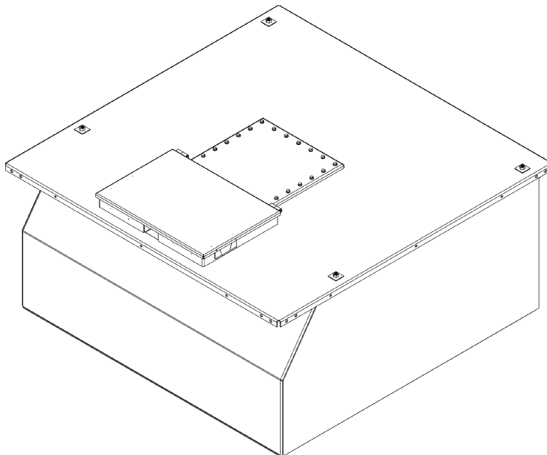

Inner tank removed from containment (20TCG shown for illustration)

## TORQUE SETTINGS

### Nuts and Bolts

If the tank is required to be dismantled and re-assembled the tank nuts and bolts used are required to be torqued, torque settings are shown in the table below.

### Metric Torque Specifications

Size	Typical Maximum Tightening Torque <b>Nm</b> ( <i>lb ft</i> )	
	Property Class	
	Grade 8.8	Grade 10.9
M8	<b>30</b> (21)	<b>40</b> (30)
M10	<b>55</b> (42)	<b>75</b> (60)
M12	<b>100</b> (74)	<b>135</b> (106)

Torque figures indicated above are valid for lightly oiled threads. Therefore, do not grease or oil bolts or cap screws unless otherwise specified.

Torque value for bolts and cap screws are identified by their head markings (property class).

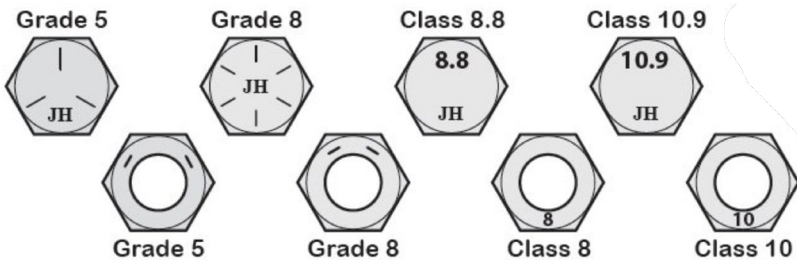

## ENVIRONMENTAL RESPONSIBILITY

Correct and considerate management of Flammable & Combustible fluids, its storage and transfer are the responsibility of everyone who operates or maintains this equipment. All necessary precautions should be made to prevent spills and subsequent pollution of the environment.

Have in place a clear action plan to deal with accidental spill, no matter how small or large. Ensure that you have a Flammable & Combustible fluids spill containment kit available and that you understand its correct use.

### Spills

Should a spill occur when emptying the containment, or when filling or transferring fuel, clear the spill as quickly as possible using absorbent material. Ideally, you should use a dedicated spill kit which will contain all the necessary items to retain and remove such a spill.

- DO NOT hose the area down or use any detergents
- DO NOT allow the fuel to enter drains or watercourses
- Spills must be reported to your local Authority
- All material used to retain and remove a spill should be bagged and collected by a registered carrier

### Containment

The TCG containment area safeguards against any spill exiting the unit and polluting the immediate area. The containment is designed to retain up to 110% of the unit's primary tank maximum storage capability.

- Check regularly for liquid in the containment
- Remove any water
- Take immediate remedial action if product or water is found

**WARNING**  
**Waste may only be collected by a registered carrier.**

### Disposal

When maintaining, servicing or disposing of the TCG or consumable components, do not dispose of contaminated parts within general refuse.

Refer to local authority regulations for their correct disposal.

## TROUBLE-SHOOTING

The Transcube is a simple and reliable system

Below we have listed common problems, causes and solutions that you may encounter.

If a problem is difficult to solve, even after having read through this trouble-shooting section, please call your local Western Global distributor or dealer.

Before you call, please have the tanks Identification Marks ready (Serial and Tank numbers)

PROBLEM	CAUSE	SOLUTION
Pump will not run	No Power	Connect power wires to correct power source
	Pump Off	Turn pump on
Fuel in containment	Loose fitting	Tighten fitting
	Leaking Coupler	Replace coupler
	Over filling	Watch fuel gauge when filling. Do not fill past 95% of the nominal capacity
Water in containment	Lid left open to weather	Keep lid closed

## WARRANTY

The Company undertakes to replace or repair, free of charge, any defect which the Company considers to be due to faulty workmanship or material within 36 months (or otherwise stated) for steel tanks from the sale date, except for:

- Defects arising from neglect, misuse or unauthorised modifications.
- Damage caused by abuse, misuse, dropping or other similar damage caused by or because of a failure to follow transportation, storage, loading or operation instructions.
- Alterations, additions or repairs carried out by persons other than the manufacturer or their recognised distributors.
- Transportation or shipment costs to and from the manufacturer or their recognised agents, for repair or assessment against a warranty claim, on any product or component.
- Materials and/or labour costs to renew, repair or replace components due to normal wear and tear.
- Faults arising from the use of non-standard or additional parts, or any consequential damage or wear caused by the fitting or use of such parts.

### **IMPORTANT**

Warranty may, at the sole discretion of the manufacturer, be voided if the scheduled service/inspections are not carried out in accordance with the logbook. The manufacturer and/or their recognised agents, directors, employees or insurers will not be held liable for consequential or other damages, losses or expenses in connection with, or by reason of, or due to the inability to use the product for any purpose.



# NEED MORE INFORMATION?

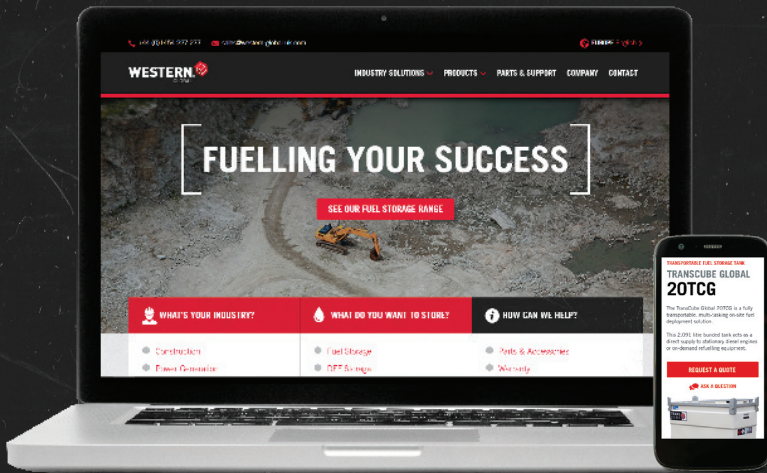

- Product Details and Specifications
- Accessories and Support Information
- Company News & Updates

**VISIT WESTERN-GLOBAL.COM**





## **HQ - WESTERN GLOBAL LTD**

Western House  
Broad Lane, Yate  
Bristol - BS37 7LD  
Tel: +44 (0) 1454 227 277  
[sales.uk@western-global.com](mailto:sales.uk@western-global.com)

### **CANADA**

Tel: +1 (0) 204 772 6525  
[info@western-global.ca](mailto:info@western-global.ca)

### **USA**

Tel: +1 (0) 203 847 4300  
[info@western-global.us.com](mailto:info@western-global.us.com)

All rights reserved. No part of this manual may be reproduced, stored in a retrieval system, or transmitted, in any form or by any means, electronic, mechanical, photocopying, recording or otherwise without the prior permission of Western Global Ltd